

Valve Package & Piping Components

BROCHURE

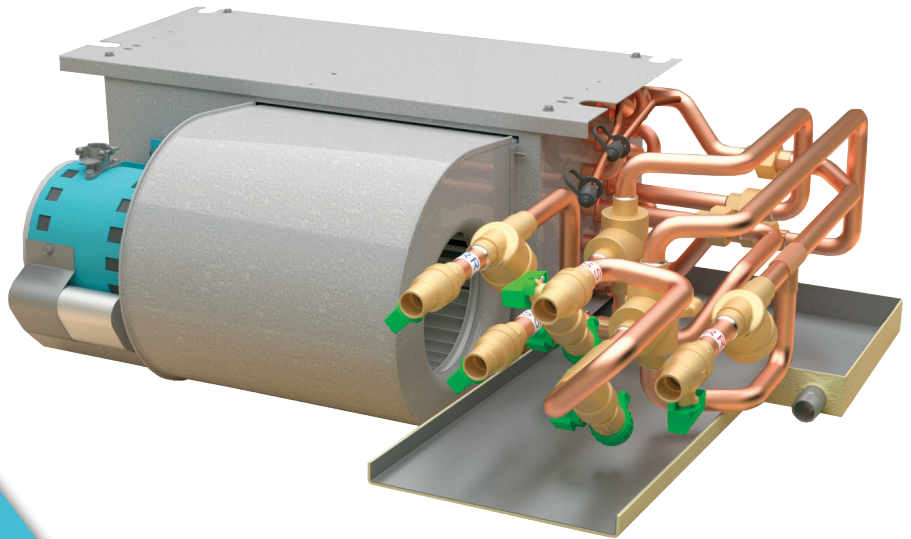

A **NIBE** GROUP MEMBER



Build your reputation on ours

Valve Packages & Piping Components

BROCHURE

International Environmental Corporation (IEC) works continually to improve its products. As a result, the design and specifications of each product may be changed without notice and may not be as described herein. Please contact IEC for information regarding current design and product specifications. Statements and other information contained herein are not express warranties and do not form the basis of any bargain between the parties but are merely IEC's opinion or commendation of its products. Manufacturer's standard limited warranty applies.

Table of Contents

- 4 Preface
- 5 Basic Definitions
- 7 Hydronic Coil Arrangement
- 8 Valve Packages
- 10 Valve Package Symbols and Placement
- 11 Valve Package Component Notes
- 12 Piping Components Chart
- 16 C_v Factor Versus Pressure Drop
- 17 System Component Working Pressure Table
- 18 Copper Water Tube and Joint Material Pressure Ratings

Valve Packages & Piping Components

BROCHURE

Preface

The information in this publication is for use by engineers and contractors using IEC products. Much of the data contained herein was compiled from various industry standards and practices. Some of the definitions and applications may not apply to equipment supplied by others.

Although due care has been taken in compilation and publication of the information stated herein, no warranties as to the accuracy or application of such information, either express or implied, are given by International Environmental Corporation (IEC) in connection herewith and IEC disclaims any responsibility for any claims arising from the use of the information contained herein.

The data contained within this publication applies to products currently in use by IEC at the time of publication, and is subject to change without notice.

Vendor component specifications were extracted from literature from others and are subject to change without notice.

Circumstances beyond IEC's control may dictate use of substitute components and/or changes in component specifications as stated herein.

Suggestions for additions, corrections, and clarification are invited.

Basic Definitions

Unit Hand

When facing the supply air outlet from the front of the unit (air blowing in you face). Chilled water piping determines the hand of the unit.

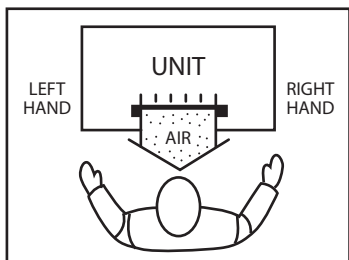

Same End Connection (4-Pipe)

All Piping connections (water and condensate drain) are on the same end (side) of the unit. Controls and electrical connection will be on the end (side) opposite the piping connection. Standard 4-pipe units will be same end connection. Chilled water piping determines the hand of the unit.

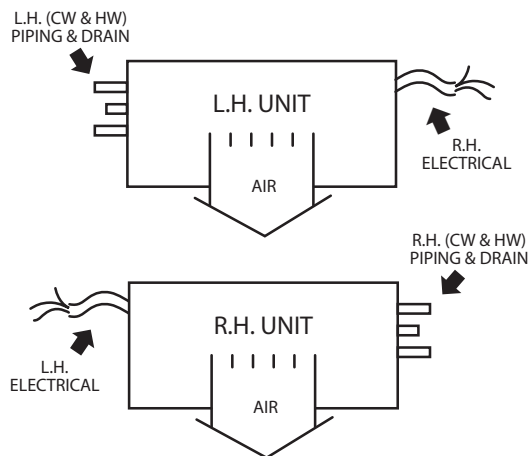

Opposite End Connection (4-Pipe Option)

Chilled water piping determines the hand of the unit. Hot water (HW) piping connections and electrical will be on the end (side) opposite the chilled water (CW) and drain connections.

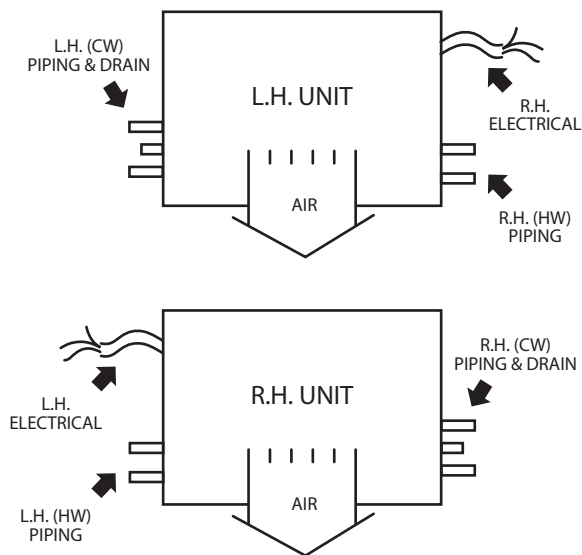

Basic Definitions, Cont'd.

Valve Packages for 2-Pipe Systems

Valve packages for standard 2-pipe units are piped for the same end connection (L.H. or R.H.). See pages 8 through 11 for further information.

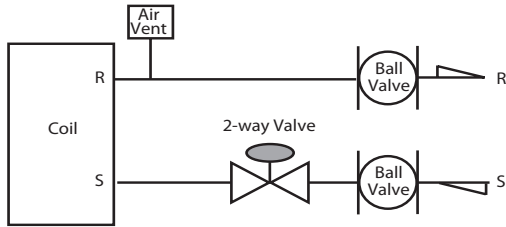

Valve Packages for 4-Pipe Systems

Using information from pages 6 through 9, select two valve packages per unit.

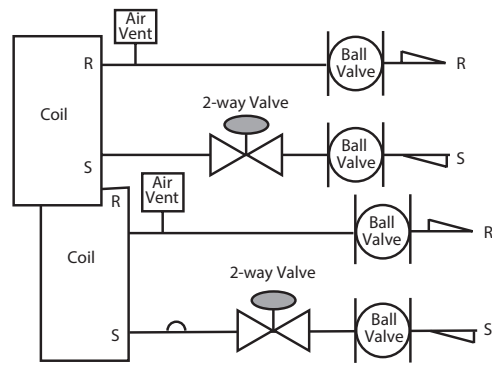
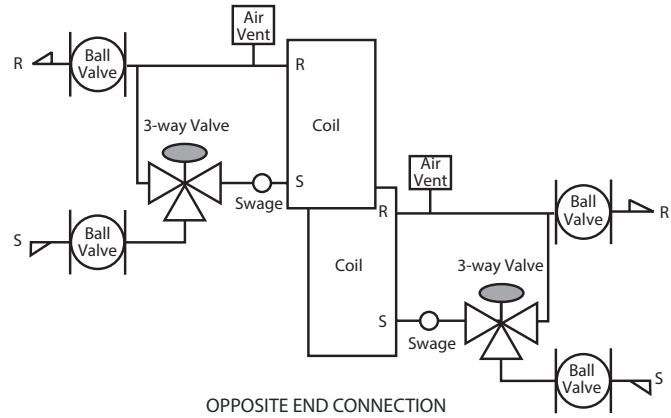

NOTE: Hot water valve package requirements may not be the same as chilled water valve packages. Control valves depicted above are considered to be standard 2 position on/off valves. Modulating valves will be located on the Return piping.

SureFlow® 1 x 2-Pipe Systems*

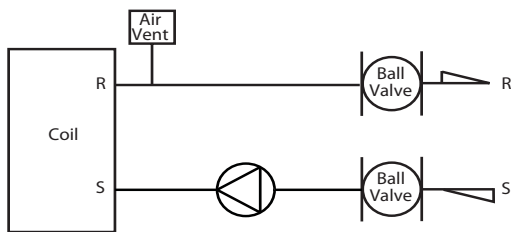

* Available with same end connection only.

SureFlow® 2 x 4-Pipe Systems*

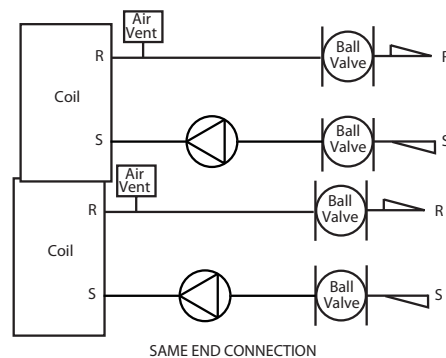

Hydronic Coil Arrangement

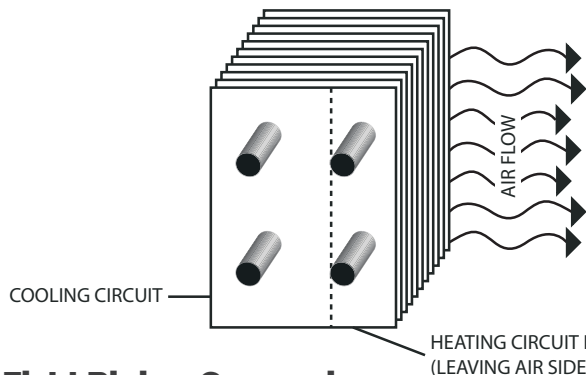

NOTE: Consult factory if heating circuit must be in preheat position. (Entering air side of coil)

Field Piping Connections

	<p>Floor Units (Exposed) FXA, FSA, LXA, LXW Pipe into cabinet end compartment (opening in bottom and back).</p>
	<p>Floor Units (Concealed) FHA, LHA, LHW Pipe to external connections (no cabinet).</p>
	<p>Ceiling Units (Exposed) CBY, CXB, HLY, HXY Pipe through knockouts in rear of cabinet to external coil and valve package connections.</p>
	<p>Ceiling Units (Concealed) CHY, CPY, HHY, HPY CHY/CPY with valve pack and pipe to connections extending from rear of unit.</p>
	<p>Vertical Units VEY, VBA (Belt Drive), VDY (Direct Drive) Pipe to stub connections extending from side of unit.</p>
	<p>Horizontal Air Handlers HBD (Belt Drive), HDY (Direct Drive) Pipe to stub connections extending through side of unit.</p>
	<p>Stud Units (Wall Recessed) STY, STW Pipe to stub connections at the side of unit or into optional compartment.</p>

NOTE: Refer to IEC submittal drawings and installation instructions for additional piping information.

Valve Packages

Valve Package Applications

Following are typical Valve Package Applications. Check your job specifications for system static pressure, close-off differential pressure drop limitations and flow rates prior to selecting valve package components or valve package size (1/2", 3/4" or 1") or components for your application.

Valve Sizing Recommendations

Valve should be sized based on the design water flow rate through the coil, pipe velocity and pressure drop through the valves. To prevent pipe erosion, IEC recommends a maximum water velocity of 8 ft./sec. That translates into the following general guidelines:

1/2" pipe:	0.5 – 5.5 gpm
3/4" pipe:	6.0 – 12.0 gpm
1" pipe:	12.5 – 20 gpm

2-Way Motorized Control Valve

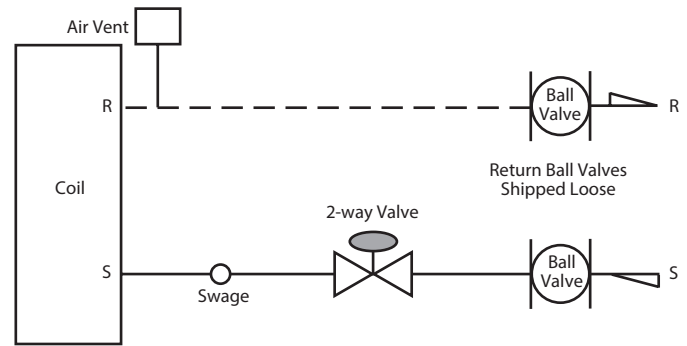

2-Way Motorized Valve–Actuator drives valve open, spring returns valve to normally closed position (no water flow with unit “off”).

Supply and return connection at coil will be swage fit for field braze (standard) or union (option).

The return connection ball valve will be shipped loose. Addition of any other component will require swage fit for field braze or optional union connection.

Basic Application

2-Pipe System Only (One Valve Package)

4-Pipe System (Two Valve Packages)

- A. 2-Pipe–Hydronic Heating Only
- B. 2-Pipe–Hydronic Cooling Only
- C. 2-Pipe–Hydronic Cooling with Total Electric Heat
- D. 4-Pipe–Hydronic Cooling and Heating

NOTE: Not recommended for 2-pipe with automatic changeover controls.

Valve Packages, Cont'd.

2-Way Motorized Control Valve with Aquastat Bleed By-Pass Line

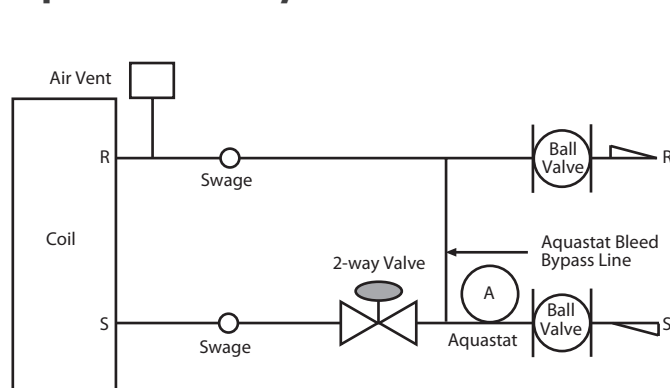

2-Way Motorized Valve—Motor drives valve open, spring returns valve to normally closed position (no water flow through coil with unit “off”).

AQUASTAT BLEED BY-PASS—Bleeds small amount of water from supply to return when control valve is closed (required for system water temperature sensing by aquastat.)

AQUASTAT/CHANGEOVER SENSOR (A)—Clips on supply line upstream from aquastat bleed by-pass (as shown above). Senses system water temperature to prevent cooling operation with hot water in system piping or heating operation with chilled water in system piping. Aquastat required to lock out the optional auxiliary electric heat when hot water in system.

Supply and return connections at coil will be swage fit for braze (standard) or unions (option).

Basic Application

2-Pipe System (One Valve Package)

- A. 2-Pipe—Hydronic Cooling and Heating
- B. 2-Pipe—Hydronic Cooling and Heating with Auxiliary Electric Heat

3-Way Motorized Control Valve

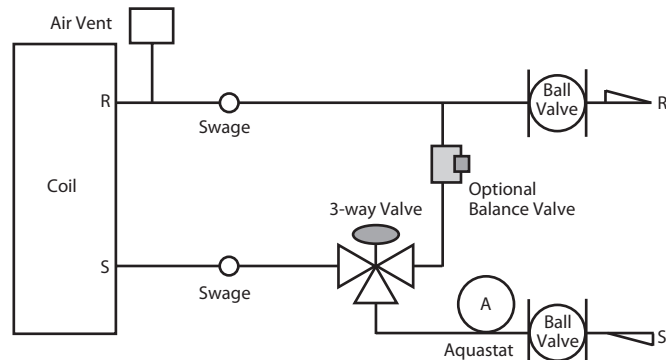

3-Way Motorized Valve—Flow normally closed to coil, open to system return. Motor closes by-pass flow to system return while opening flow through coil. Water by-passes coil and flows directly to system return when unit is “off.”

BY-PASS BALANCING VALVE—A balancing valve may be specified in the by-pass line to permit equal flow balancing.

Supply and return connections at coil will be swage fit for field braze (standard) or union (option).

Basic Application

2-Pipe System Only (One Valve Package) or 4-Pipe system (Two Valve Packages)

- A. 2-Pipe—Hydronic Heating
- B. 2-Pipe—Hydronic Cooling
- C. 2-Pipe—Hydronic Cooling and Heating
- D. 2-Pipe—Hydronic Cooling and Heating with Auxiliary Electric Heat
- E. 2-Pipe—Hydronic Cooling with Total Electric Heat
- F. 4-Pipe—Hydronic Cooling and Heating

Valve Package Symbols and Placement

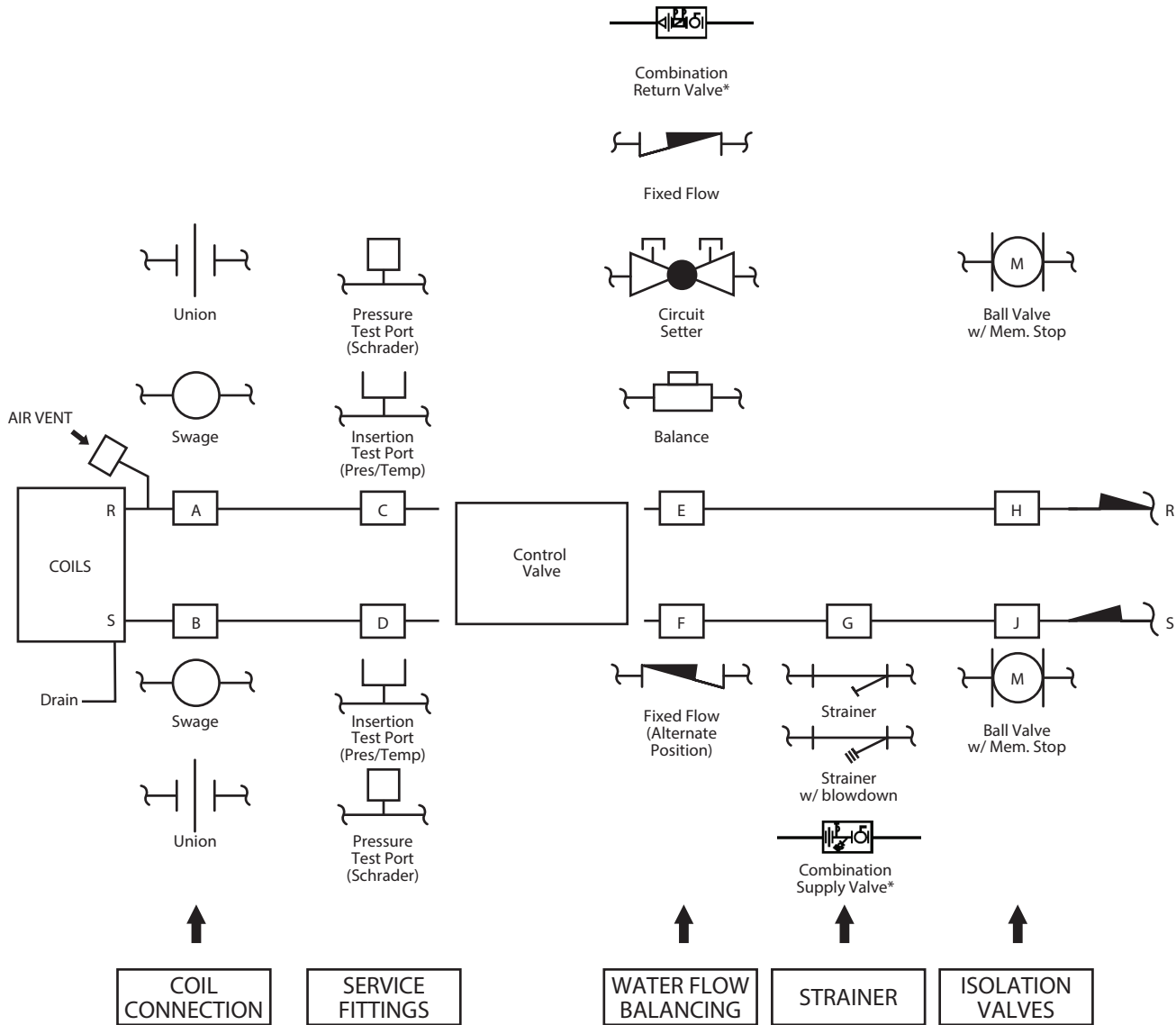

* Available for Horizontal Ceiling Valve Packages.
For application in other units, contact factory.
Combination valves will also take the place of the ball valve because they include an isolation shut off valve.

General Information

Special Components

Consult factory prior to specifying valve package components that are not described in this manual.

Shipping

Valve packages must ship packed with units or in unit cartons. Valve packages that are not brazed to coil stub-outs are "DRY FIT" to matching coil prior to packing.

Condensate Control

Factory supplied cooling valve packages will be arranged to position as much of the package as possible over an auxiliary drain pan or drip lip. This serves to minimize requirements for field piping insulation.

NOTE: Strainers, flow control valves and balance valves are not required or allowed with the use of SureFlow® circulators.

Valve Package Component Notes

Component Size

1/2" nominal (for 5/8" OD copper tubing) or 3/4" nominal (for 7/8" OD copper tubing.) Mega Mod (MGY) units may be ordered with limited 1" nominal.

Manual Air Vent

Standard component—Brazed into high point of hydronic cooling and/or heating coil circuit.

Automatic Air Vent

Brazed into high point of coil circuit.

Coil Connections (A and B)



STANDARD: Swage fitting for field braze.

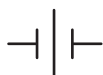

OPTION: Union(s) added by factory for field connection.

Service Fittings (C and D)

Optional fittings for attaching pressure/temperature sensing devices.



PRESSURE TEST PORT: Pressure test only—In supply and return lines.



INSERTION TEST PORT (PT Port): Pressure/Temperature test—In supply and return lines.

Water Flow Balancing (E, F and H)

Used for balancing water flow through the coil.



CIRCUIT SETTER



BALANCING VALVE: Check specifications for service fitting requirements.



FIXED FLOW: No balancing required.

Consult your factory representative to match the available fixed flow valve to your job requirements.



COMBINATION RETURN VALVE: Includes union, ball valve, fixed flow valve and two P-T ports. Consult factory representative to match fixed flow to job requirements.

Strainer (G)

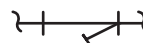

Should not be used in lieu of main piping strainers.



Strainer with blowdown

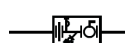

COMBINATION SUPPLY VALVE: Includes union, ball valve, Y-strainer with blowdown and P-T port.

Isolation Valves (H and J)

Normally requires one each on supply and return line.

When position H is used for balancing (ball valve or ball valve with memory stop), check specifications for service valve requirements.





BALL VALVE: Shut-off/balance—No memory stop.



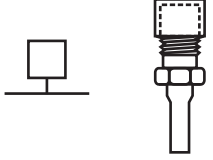
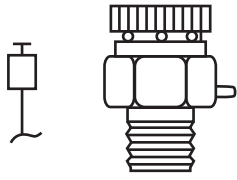

BALL VALVE WITH MEMORY STOP: Shut-off/balance—Memory stop allows re-opening to balance point after usage as a shut-off.

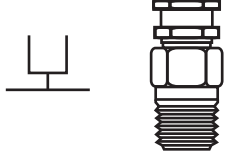

Piping Components Chart

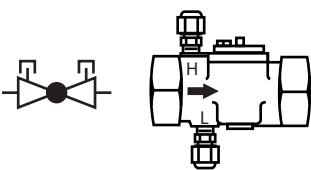
Symbol/Sketch	Description	C _v Factor		Rating	
		1/2"	3/4"	PSI	° F
	<p>Pressure test Port: Brass body 1/4" service access fitting with removable depressor type core.</p> <p>Application: Installed on both side of the coil to allow for pressure sensing. Attach pressure gauges to facilitate water balancing.</p>	N/A	N/A	400	210
	<p>Automatic Air Vent: Nickel plated brass valve, fiber-disc type, with positive shut-off ballcheck and quick vent feature via knurled vent screw.</p> <p>Application: Optional replacement for manual air vent. Automatically passes minute quantities of air through the fiber discs which expand upon contact with water, completely sealing the valve. As air accumulates, the fiber discs dry and shrink, repeating the cycle. Not recommended for removing large quantities of air encountered during initial start-up or subsequent draining and refilling. Should not be used in lieu of main system air vents.</p> <p>Note: Not recommended for use in systems with glycol.</p>	N/A	N/A	125	240
	<p>Swage: Copper tube end expanded to accept a copper tube of the same size for factory or field brazing.</p> <p>Application: Used where possible for all tubing joints for best joint integrity.</p> <p>* See page 21 for ratings of different joining materials and operating temperatures.</p>	N/A	N/A	300 (*)	200 (*)
	<p>Union: Combination wrought copper/cast brass union assembly, solder by solder.</p> <p>Application: Used for quick connect (and disconnect) of valve package components to minimize field labor and facilitate servicing of unit.</p> <p>* See page 21 for ratings of different joining materials and operating temperatures.</p>	-	N/A	300 (*)	200 (*)
	<p>Insertion Test Port: Brass body valve for acceptance of test probe (up to 1/8" diameter).</p> <p>Application: Installed on one (or both) sides of the coil to allow for temperature or pressure sensing. Used for water balancing and service analysis.</p>	N/A	N/A	250	250

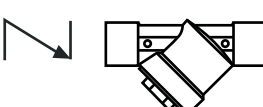
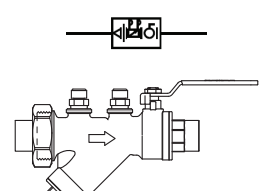
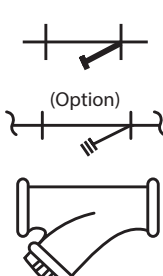

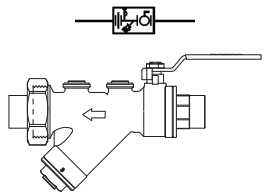
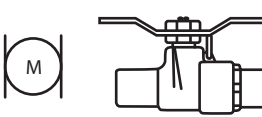
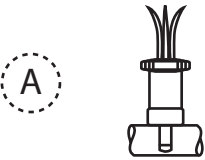

Piping Components Chart, Cont'd.

Symbol/Sketch	Description	C _v Factor			Rating	
		1/2"	3/4"	1"	PSI	°F
	<p>Circuit Setter: Variable water flow balancing valve with manual adjustment, pointer, percent-open scale, memory stop and integral pressure read-out ports.</p> <p>Application: Used for water flow balancing.</p>	Taco – Pressure Ports Only				
		2.12	3.9	8.4	300	250
	<p>Balance Valve: Variable water flow manual balancing valve with screwdriver slot adjustment screw.</p> <p>Application: May be used in 3-way valve by-pass line to permit equal flow balancing.</p>	B&G – Pressure and Temperature Insertion Ports				
		1.6	3.4	5.8	200	250
	<p>Fixed Flow Valve: Flexible orifice type (non-adjustable).</p> <p>Application: Used for water flow balancing. Valve automatically adjusts the flow to within 10% of set point. Operating range: 2-80 PSID</p>	Valve orifice size determines C _v factor. The orifice of these fixed flow valves changes as flow is regulated. As the water pressure increases, the orifice size decreases, thereby automatically limiting the flow rate to the specified GPM (+/- 10%).			600	220
	<p>Combination Return Valve: Includes union, ball valve, fixed flow control and two P-T ports.</p> <p>Application: Instead of adding individual components, utilize the combination valve to save cost. Fixed flow used for water flow balancing.</p>	Valve orifice size determines C _v factor. The orifice of these fixed flow valves changes as flow is regulated. As the water pressure increases, the orifice size decreases, thereby automatically limiting the flow rate to the specified GPM (+/- 10%).			600	220
	<p>Strainer: Y-type strainer (with blowdown option) body with 20 mesh stainless steel screen.</p> <p>Application: Used for removal of small particles from system water during normal system operation. Should not be used in lieu of main system strainers. Strainer screen may have to be removed during initial high pressure system flushing during start-up. Screen should be removed and cleaned per normal maintenance schedule (provisions for strainer blow-down not provided).</p>	5.5 Clean	9.0 Clean	–	600	325

Piping Components Chart, Cont'd.

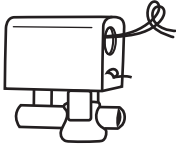
Symbol/Sketch	Description	C _v Factor			Rating	
		1/2"	3/4"	1"	PSI	° F
	<p>Combo Supply Valve: Includes union, ball valve, y-strainer with blowdown, P-T port.</p> <p>Application: Instead of adding individual components, utilize the combination supply valve to save cost. Y-strainer with blowdown used for removal of small particles from system water during normal system operation. Should not be used in lieu of main system strainers. Strainer screen may have to be removed during initial high pressure system flushing during start-up. Screen should be removed and cleaned per normal maintenance schedule (provisions for strainer blow-down not provided).</p>	5.5 Clean	9.0 Clean	–	600	325
	<p>Ball Valve with Memory Stop: Manual balance and shut-off valve.</p> <p>Application: Unit isolation and water flow balancing. The adjustable memory stop feature allows return to the balance point after shut-off.</p>	Full Port	Full Port	–	600	325
	<p>Aquastat/Changeover Sensor: Water temperature sensing electrical switch.</p> <p>Application: Clips directly on nominal size 1/2" or 3/4" copper tubing for water temperature sensing. Must be correctly located for proper control operation.</p>	–	–	–	–	–
	<p>SureFlow® Circulator: Each circulator includes a removable integral check valve to prevent gravity flow and reduce installation costs. An anti-condensate baffle prevents the build up of condensate on the motor windings when pumping chilled water. Replacing the cartridge rebuilds the circulator. With no mechanical seal, the self-lubricating maintenance-free design provides unmatched reliability.</p> <p>Sizes: 006, 008. Bronze casing.</p>	–	–	–	200	220

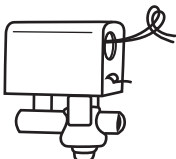
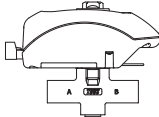
Piping Components Chart, Cont'd.

Symbol/Sketch	Description	Cv Factor			Rating			
		1/2"	3/4"	1"	Close-off, psi	Static, psi	Temp, F	
 	<p>Erie 2-Way Motorized Valve: Electric 2-position zone flow control valve (open/closed). Normally-closed body with manual override lever. Installed in supply line to unit.</p> <p>Application: All standard controls and valve packages are based upon normally-closed valves (valve electrically powered open and closed by spring return when electric power removed). Manual override lever allows valve to be placed in the open position for emergency operation, constant water flow prior to start-up, etc. Manual override is automatically disengaged when valve is electrically activated. Consult factory for normally-open valve applications.</p>	2.5	2.5	-	40	300	200 Fluid (104 Ambient)	
		3.5	3.5	-	25			
		-	5.0	-	20			
		-	-	8.0	17			
 	<p>Erie 3-Way Motorized Valve: Electric 2-position zone flow control valve (closed to coil/open to by-pass or open to coil/closed to by-pass). Normally-closed with manual override lever. Installed in supply line to unit.</p> <p>Application: Same comments as 2-way motorized valve except when manual override lever engaged the valve is open to both ports and water flow will take the path of the least resistance through the valve package (not necessarily 100% through the coil).</p>	3.0	3.0	-	40	300	200 Fluid (104 Ambient)	
		4.0	4.0	-	25			
		-	5.0	-	20			
		-	-	7.5	17			
 	<p>Taco 2-Way Motorized Valve: Electric position zone flow control valve. Normally -Closed (NC) and Normally-Open (NO) body with manual override knob available. Installed in the supply line to unit.</p> <p>Application - NC valve: Valve electrically powered open and closed by spring return when electric power removed. Manual override knob allows valve to be placed in the open position for emergency operation, constant water flow prior to start-up, etc. Manual override is automatically disengaged when valve is electrically activated.</p>	4.9	-	-	150	300	220 Fluid (135 Ambient)	
		-	10.3	-				
		-	-	8.9				
	<p>Application - NO valve: Valve electrically powered closed and opened by spring return when electric power removed. Commonly applied to hot water valves only where hot water is required to run continuously through the coil to avoid freezing.</p> <p>Manual override knob allows valve to be placed in the closed position for emergency operation. Manual override is automatically disengaged when valve is electrically activated.</p>	<p>Taco 3-Way Motorized Valve: Electric 2-position zone flow control valve with manual override knob available. Installed in supply line to unit.</p> <p>Normally -Closed (NC) - closed to coil/open to bypass.</p> <p>Normally-Open (NO) - open to coil/closed to bypass or close to coil/open to bypass.</p> <p>Application: Same comments as 2-way motorized valve.</p>	4.9	-	-	150	300	220 Fluid (135 Ambient)
			-	3.3	-			
			-	-	3.0			

C_v Factor Versus Pressure Drop

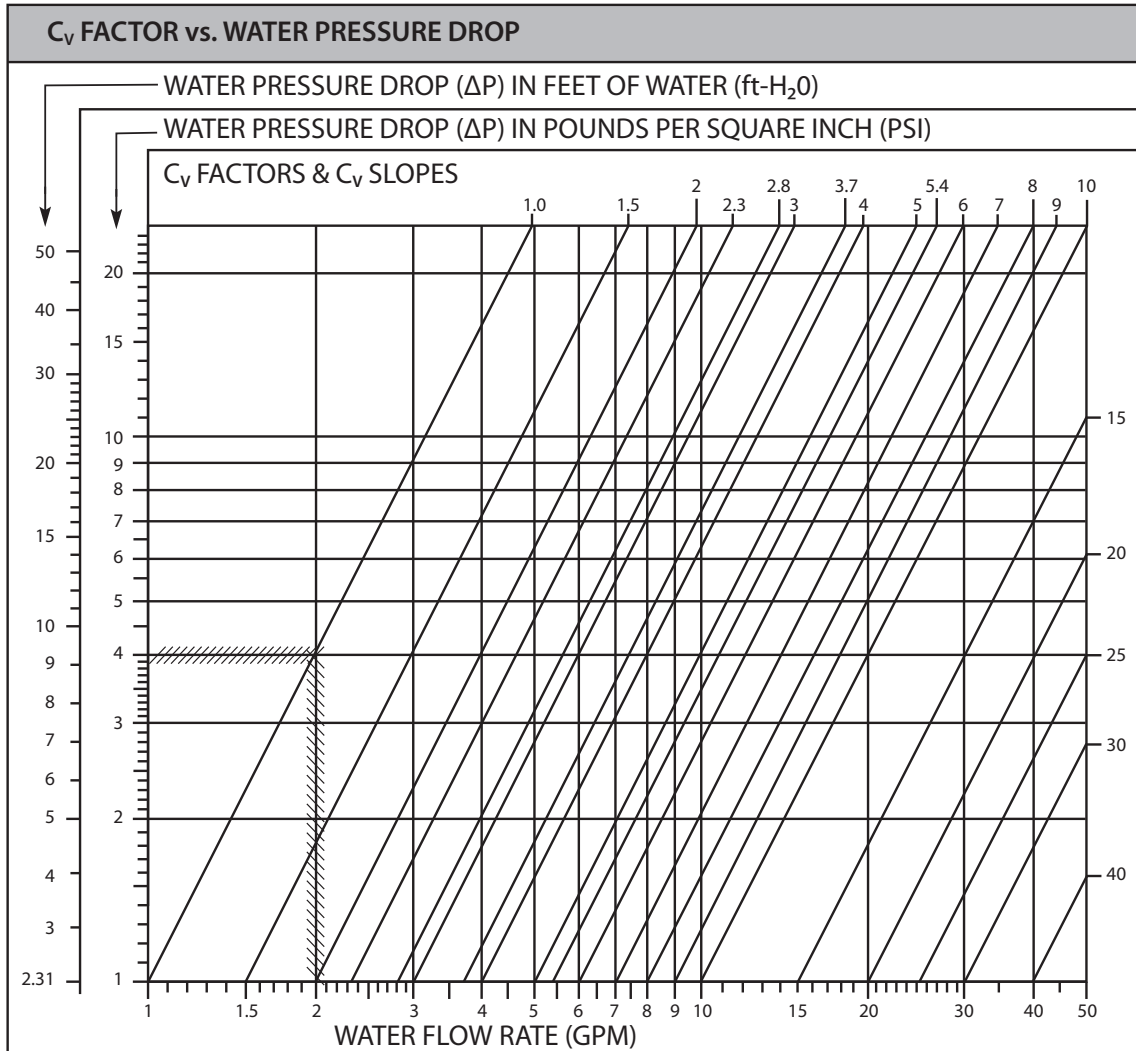

C_v Factor

The flow rate in gallons per minute (GPM) through a piping component when the pressure drop (ΩP) in pounds per square inch (PSI) across the component is 1.0 (PSI).

Pressure drop (ft-H₂O) = 2.31 x PSI (pressure drop)

Graph Example

ΩP for 2.0 GPM through a component with a C_v of 1.0 is 4.0 PSI x 2.31 = 9.24 ft-H₂O

Formula Example

ΩP (ft-H₂O) = (GPM)² / (C_v)² x 2.31 = (2.0)² / (1.0)² x 2.31 = 9.24 ft-H₂O or (GPM) / (0.658 x C_v)²

TOTAL PRESSURE DROP is the Sum of the pressure drop of all piping and components in the water flow path.

System Component Working Pressure Table

System Working Pressure (PSIG)		125	150	200	250	300	350	400	
Joint Material		95/5 Tin-Antimony					6% Silver Solder		
Factory Piping and Fittings									
Other Components	Riser Drain Hose Bibb†								
	Manual Air Vent								
	Auto Air Vent								
	Union								
	Strainer								
	Gauge Cock†								
	Pete's Plug								
Adjustable Flow Control	Taco Accu-Flow								
	Balance Valve								
	B and G Circuit Setter								
Fixed Flow Control	Hays 2517								
Electric Motorized Valves	Taco	Sweat Type							
	Erie								
SureFlow® Circulator	Taco								
Isolation Valves	Ball								
Coil (DWP/TEMP)		Standard Coil Construction 250 PSIG at 200° F Water or 15 PSI Steam				Option 1 300 PSIG at 200° F	Option 2 350 PSIG at 150° F	Option 3 400 PSIG at 100° F	

† Special components, consult factory

Valve Packages & Piping Components

BROCHURE

Copper Water Tube and Joint Material Pressure Ratings

Copper Tube			Safe Working Pressure (PSI)						
Nom. Size	Wall	Type	100	200	300	400	500	600	
3/4	.065	K							860
	.045	L						570	
	.032	M				400			
1	.065	K							660
	.055	L					490		
	.035	M				330			
1-1/4	.065	K						530	
	.055	L					440		
	.042	M				330			
1-1/2	.072	K	(A)	(B)	(C)	(D)	(E)	(F)	500
	.060	L						410	
	.049	M					330		
2	.083	K						420	
	.070	L						370	
	.058	M				290			
2-1/2	.095	K					400		
	.080	L					340		
	.065	M				270			
3	.109	K						390	
	.090	L					320		
	.072	M			250				
4	.134	K						360	
	.110	L					290		
	.095	M			250				

Legend:

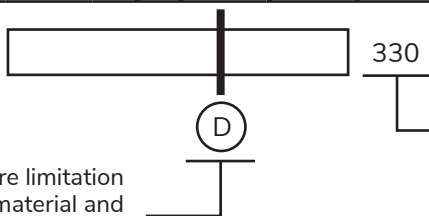

System pressure limitation due to joint material and water temperature

Maximum safe working pressure (PSI) for copper water tube alone at 200° F. Nominal size tube shown, add 1/8" to obtain actual tube O.D.

Joint Material					
A	50-50 Lead-Tin at 200° F	Note 1	D	95-5 Tin-Antimony at 200° F	Note 2
B	50-50 Lead-Tin at 150° F		E	95-5 Tin-Antimony at 150° F	
C	50-50 Lead-Tin at 100° F		F	95-5 Tin-Antimony at 100° F	

The above chart is for reference only: Check all system component pressure ratings (coils, valves, pumps, etc.) and any applicable local or national piping codes prior to specifying system pressure rating.

- NOTES: 1. Not recommended for high system water pressure.
 2. Standard factory joint material.

This page intentionally left blank.

Valve Packages & Piping Components

BROCHURE



Contact your local IEC Sales Representative for further details and pricing applicable to this product. Visit our website (iec-okc.com) to find your local IEC Sales Rep.

IEC Part Number: I100-90007695
GU-290 Revision 6 (08/2022)

©2000-2022 International Environmental Corporation (IEC)



5000 W. I-40 Service Rd.
Oklahoma City, OK 73128
P: 405.605.5000
F: 405.605.5001
www.iec-okc.com